

# 1274 Magneto Installation Instructions

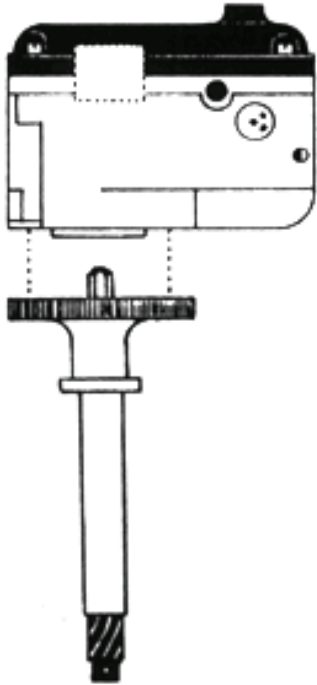

Fig. 1

1. To install the magneto remove the spark plug from the forward cylinder. Next remove the distributor cover on the stock ignition while still in the bike. Crank the engine over until the piston in the front cylinder is coming up on compression and the points begin to open. This should put you very close to 32 to 35 degrees advance. Take the bike out of gear now and leave it that way until you have the magneto installed and are ready to start it. Some stock ignitions have built-in advance mechanisms and after you have installed the magneto, you will have to alter the timing to compensate for this extra advance.

2. Remove the four Allen socket head screws, holding the base to the magneto housing and separate the base from housing (Fig. 1).

3. This unit comes with 2 spacers. One c-spacer and one 1/4" round spacer. The c-spacer goes under the flange on the magneto base. The 1/4 round goes on the hold down stud to space the hold down clamp up. By installing the c-spacer and round spacer, you will be raising the unit. The bike will be timed and run with both spacers installed

4. Insert base into engine making sure that it bottoms out and is perfectly flat on the machined surface on the engine case. **Note:** Make absolutely sure that nothing hits the base or obstructs it from bottoming on the machined surface on the case. If it does not bottom correctly, relieve adapter or cases so that it does. If you have to relieve the adapter, make sure to relieve it enough to have sufficient clearance to advance or retard for timing purposes.

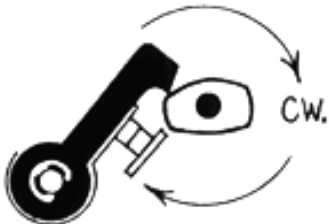
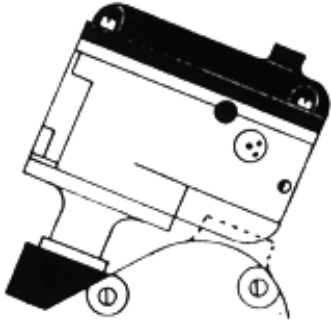

Fig. 2

5. Remove the cap on the magneto housing and turn the magneto clockwise so that the small lobe on the cam is about to open the points (Fig. 2). While maintaining this cam position set the housing back onto the base. **Note:** Most Panhead models will have to be mounted with the coil hold down screws on the magneto facing toward the front of the bike and parallel approximately with the barrels while other models will mount with the coil hold down screws facing straight out the side.



#### On Panhead Models:

To mount the magneto it will be necessary to remove and relocate your relay if it is mounted on the boss that is cast into the case. It will also be necessary to partially or totally remove the boss that the relay previously sat on. This can be accomplished with a hacksaw with the blade turned sideways. Cleanup can be done with a file, disc sander, hand grinder, emery paper, etc. The casting is thick in this area, so make sufficient clearance for the mag. If necessary, a small amount can be relieved on the bottom of the magneto. Some fins may also have to be relieved slightly for clearance. This can be done with a hand grinder, cape chisel, etc.

#### All Other Models:

Fins may need to be slightly relieved around the magneto housing to create clearance for advancing and retarding the magneto. For pushrod housing clearance you may have to dimple your pushrod housing or slightly relieve the side of the magneto and cap in the area that makes contact with the pushrod cover.

6. After making sure there is sufficient clearance around the magneto to advance and retard the unit, apply Loctite to the four Allen socket head screws and install them tightly, affixing the base to the magneto housing permanently

7. Install the hold down clamp leaving it loose enough to still turn the magneto by hand.

8. Rotate the magneto counter-clockwise until the points just begin to open, and lock it down.

9. Place cap on magneto and install plug wires. **Note:** When using a magneto ignition system, copper or stainless steel solid core spark plug wires and non-resistor spark plugs are required for optimum performance.

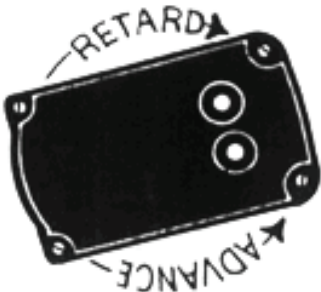

10. Connect kill switch to ground terminal stud located on the side of the magneto housing. Start the bike and adjust the timing as necessary to achieve the desired idle. Turning the magneto housing counter clockwise will advance the timing and clockwise will retard the timing.

\* The magneto points are preset at the factory, but may need to be checked from time to time due to normal wear. The points should be gapped at (0.015" to 0.16")